

# Attiva<sup>C</sup>

design: Ambostudio

**ATTIVA è una famiglia di sedute direzionali ed operative molto innovative e di alto livello qualitativo. Le finiture cromate lucide, la rete elastica dello schienale e l'innovativo sistema di molle protette all'interno del sedile creano una simbiosi di comfort ed eleganza. Il design è molto accattivante, si caratterizza per le sue linee forti e decise. È disponibile con due tipologie di schienale alto oppure basso, e due tipologie di braccioli.**

*ATTIVA is a family of very innovative and high quality executive and operative chairs. The polished chrome finish, the elastic mesh backrest and the innovative spring system protected inside the seat create a symbiosis of comfort and elegance. The design is very attractive, characterized by its strong and decisive lines. It's provided with high or low backrest, and two types of armrests.*

*ATTIVA est une famille de fauteuils opératifs et de direction de haut niveau et design. Les finitions chromées brillantes, la maille élastique du dossier et le système de ressorts "protégés" à l'intérieur de l'assise créent une symbiose de confort et élégance. Le design est captivant, caractérisé par des lignes fortes et attractives. Attiva est disponible avec dossier haut ou bas, et avec deux types d'accoudoirs.*

*ATTIVA ist eine innovative und hochwertige Drehstuhlfamilie geeignet im Direktionsbereich und Sekretariat. Die verchromte und glänzende Feinbearbeitungen, das elastische Netz der Rücklehne und das innovative Federungssystem im Sitz eingebaut erlauben eine lineare und einnehmende Symbiose zwischen Komfort und Eleganz. Das Design ist sehr attraktiv und kennzeichnet sich durch starke und klare Linien. Verfügbar mit hohe oder niedrige Rücklehne und mit zwei verschiedene Armlehnen.*

*ATTIVA es una familia de sillas ejecutivas y operativas muy innovadoras y de alta calidad. Los acabados en cromo pulido, el respaldo elástico y el innovador sistema de resortes dentro del asiento crean una simbiosis de confort y elegancia. El diseño es muy cautivador, se caracteriza por sus líneas fuertes y pronunciadas. Está disponible con dos tipos de respaldo alto o bajo y dos tipos de brazos.*







TOP COLLECTION



## AttivaC

Girevole, schienale in rete, traverso "C", molle sedile. Schienale medio o alto.

*Swivel, "C" bar, mesh backrest, seat springs. Medium or high backrest.*

Pivotant, traverse "C", dossier en résille, ressorts assise. Moyen ou haut dossier.

*Drehbar, Querstange "C", Netz Rückenlehne, Federkern im Sitz. Mittlere oder hohe Rückenlehne.*

Giratoria, respaldo de malla, travesaño "C", resortes en el asiento. Respaldo medio o alto.

versions  
**Medium**  
**High**  
**High+headrest**

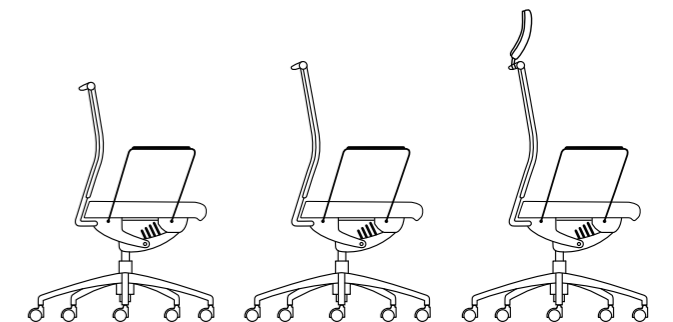



**AttivaC**  
Headrest

\_132



**AttivaC/High**  
AT0039+XT001+XB087

133





**AttivaC /High**  
**AT0039+XC020+XB087**

TOP COLLECTION

# AttivaC

High



**AttivaC /High**  
**AT0008+XB001+XC020**



TOP COLLECTION

# AttivaC

High



**AttivaC /High**  
AT0008+XB084+XR006



**AttivaC /High**  
AT0039+XB001+XR006



TOP COLLECTION

**AttivaC**

138



139

Poland

AttivaC



TOP COLLECTION

# AttivaC

Medium



**AttivaC /Medium**  
**AT0206+XB003+XR006**



**AttivaC /Medium**  
**AT0230+XB092+XR006**



# AttivaC

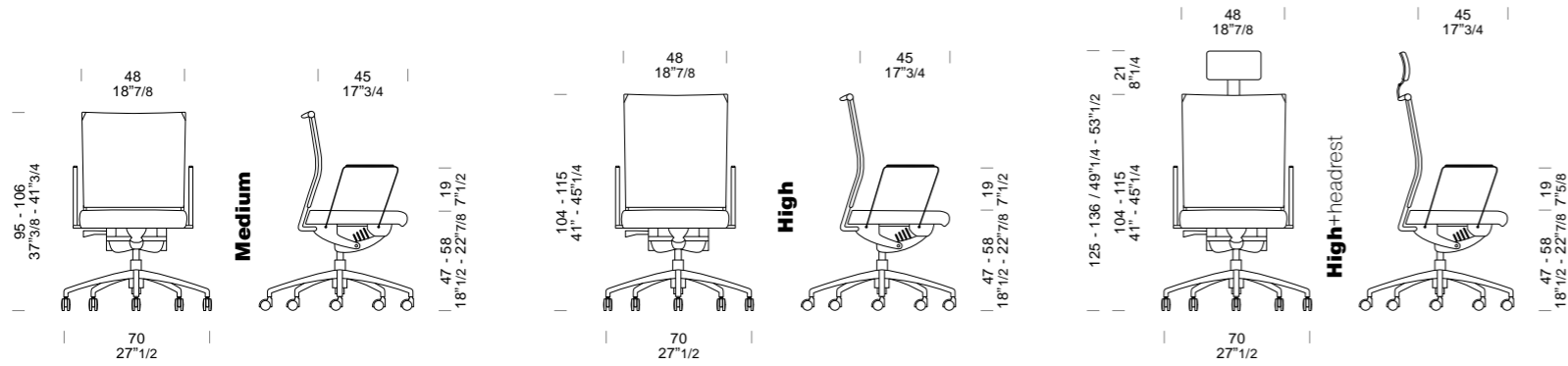

# AttivaC



**A** Pressione sullo schienale di spalle e scapole  
Shoulders and scapulas pressure on backrest  
Pression des épaules et omoplates sur le dossier  
Druck von der Schulter und Schulterblatt auf der Rückenlehne  
Presión en la parte posterior de los hombros y omóplatas

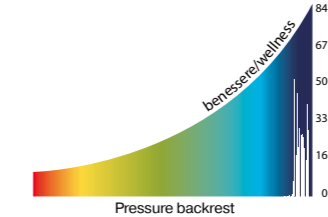

**B** Pressione dell'area sacrale su supporto lombare  
Sacrum pressure on lumbar support  
Pression sacrale sur le soutien lombaire  
Druck im Bereich Kreuzbein und Lendenwirbelstütze  
Presión del área sacra sobre soporte lumbar

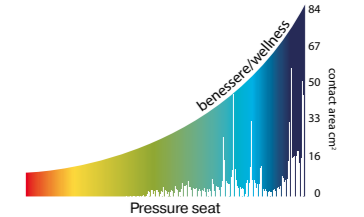

**C** Pressione di bacino e cosce sul sedile  
Hip and thigh pressure on seat  
Pression des cuisses et du bassin sur l'assise  
Druck im Becken und Oberschenkel auf dem Sitz  
Presión de pelvis y muslos en el asiento

**SCHIENALE:** Schienale in tubo sagomato d'acciaio, Ø 25mm, finitura cromata (15µm) rivestita in rete o imbottita con spugna e rivestita in tessuto.

**BACKREST:** Ø25mm shaped steel tube backrest, chromed finish (15µm), mesh upholstered or foam padded and fabric upholstery.

**DOSSIER:** Dossier en tube d'acier formé, Ø 25mm, finition chromé (15µm), revêtue en résille ou rembourrée de mousse et tapissée.

**RÜCKENLEHNE:** Ø25mm geformte Stahlrohr Rückenlehne-verchromt (15µm), Netzrücken oder gepolsterten Schaumstoff.

**RESPALDO:** Parte posterior en tubo de acero con forma, Ø 25 mm, acabado cromado (15 µm) en malla o acolchado con espuma y tapizado.

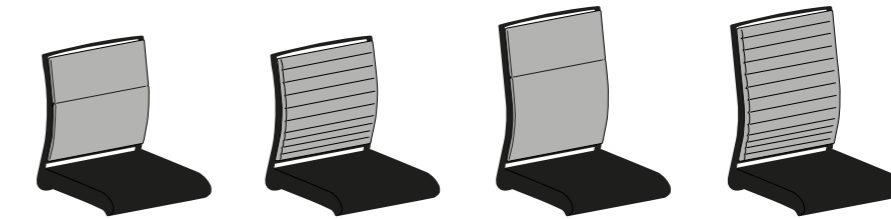
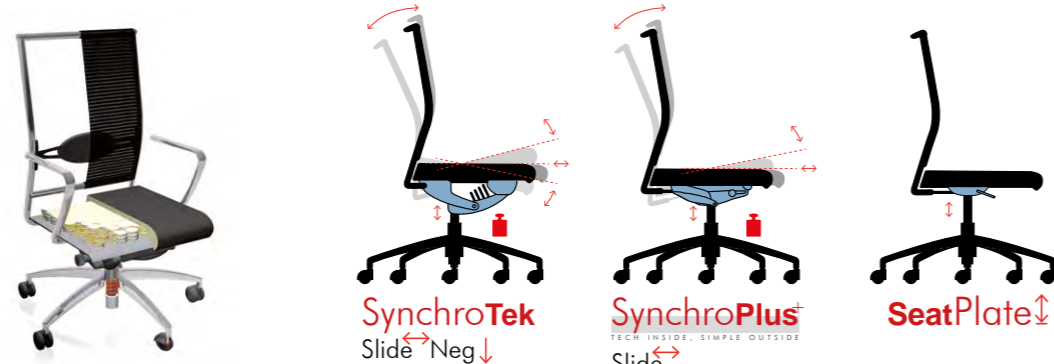

**XC013**  
medium cushion

**XC021**  
medium cushion

**XC012**  
high cushion

**XC020**  
high cushion



5-spoke  
polished aluminium base

5-spoke  
chromed iron base

4-spoke  
polished aluminium base

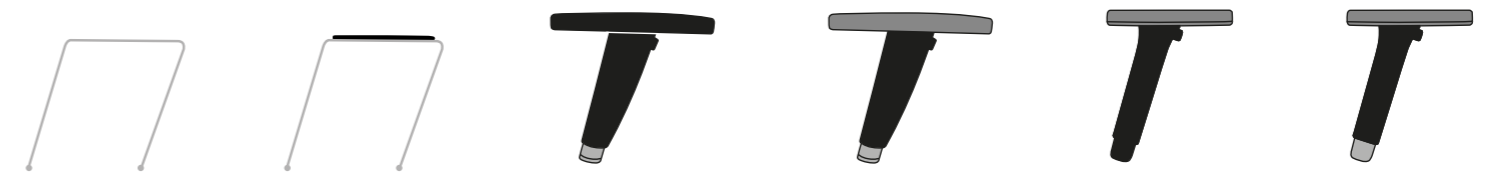

**XB001**  
metal arm.

**XB002**  
metal arm. uph. pad

**XB092**  
chromed 3D

**XB087**  
chromed 3D  
soft pad

**XB089**  
4D extra soft pad

**XB090**  
chromed 4D  
extra soft pad



Ø 50 mm  
soft self-braking,  
chromed finish

Ø 65 mm  
soft self-braking,  
black finish

Ø 65 mm  
self-braking  
perforated

h 25 mm  
chromed finish

h 68 mm  
chromed finish

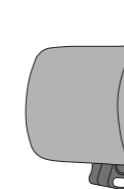

**XT001**  
headrest

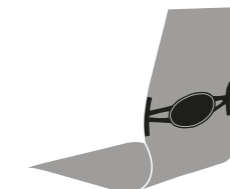

**XR006**  
lumbar support



**XD004**  
seat with springs

Per approfondimenti su meccanismi, braccioli e certificazioni consultare la sezione tecnica a pag. 24. / For further information on mechanisms, armrests and certifications, consult the technical section on page 24. / Pour plus d'informations sur les mécanismes, les accoudoirs et les certifications, consultez la section technique p. 24. / Weitere Informationen zu Mechanismen, Armlehnen und Zertifizierungen finden Sie im technischen Abschnitt auf Seite 24. / Para más información sobre mecanismos, brazos y certificaciones, consulte el apartado técnico en p. 24.

