

Otavo

idea: *Pietro Lovato*

La famiglia OTAVO racchiude in sé l'essenza della seduta da ufficio: le quattro versioni girevoli Q, R, D e P disponibili rispondono alle più varie necessità.

Dal bisogno di comfort, praticità, così come di ergonomia e resistenza, la sedia OTAVO si distingue per la sua adattabilità.

È disponibile anche con quattro gambe o slitta. Numerosi colori e materiali di rivestimento completano l'offerta di queste sedute competitive.

The OTAVO family embodies the essence of the Office chair: the four swivel versions available Q, R, D, and P, meet the most different needs. From the need for comfort, convenience, as well as ergonomics and endurance, the OTAVO chair stands out for its adaptability. It's also available with four legs or cantilever. Numerous colors and upholstery materials complement the offerings of these competitive seats.

La famille Otavo exprime l'essence du siège de bureau : Q, R, D et P, les quatre versions pivotantes Q, R, D et P, répondent aux besoins les plus variés. De la nécessité de confort, à l'aspect pratique, ainsi que à l'ergonomie et à la résistance, le siège OTAVO se distingue par sa capacité d'adaptation. Il est également disponible en quatre pieds et luge. De nombreuses couleurs et matériaux de revêtement complètent l'offre de ces sièges compétitifs.

Stühle. Die OTAVO-Stuhlfamilie umschließt die Essenz des Bürostuhls. Die vier verfügbare Versionen Q, R, D und P erfüllen die unterschiedlichsten Anforderungen. Von dem Bedürfnis nach Komfort, Bequemlichkeit sowie Ergonomie und Ausdauer, unterscheidet sich der OTAVO Stuhl für seine Anpassungsfähigkeit. Vorhanden ist diese Stuhlfamilie auch mit 4-Fuß oder Freischwinger Gestell. Zahlreiche Gewebefarben vervollständigen das Angebot dieser Wettbewerbs Stühle.

La familia OTAVO encarna la esencia de la silla de oficina: las cuatro versiones giratorias Q, R, D y P disponibles satisfacen las necesidades más variadas. De la necesidad de comodidad, practicidad, a la ergonomía y durabilidad, la silla OTAVO destaca por su adaptabilidad. También está disponible con cuatro patas o trineo. Numerosos colores y materiales de recubrimiento completan la oferta de estos asientos competitivos.





352

OPERATIVE COLLECTION



OtavoQ

Girevole, imbottita, supporto lombare regolabile. Schienale regolabile in altezza.

Swivel, upholstered, adj. lumbar support. Adjustable backrest.

Pivotant, rembourré, soutien lombaire régl. Dossier réglable en hauteur.

Drehbar, gepolstert, Lumbalstütze. Höhenverstellbare Rückenlehne.

Giratoria, acolchada, soporte lumbar ajustable. Respaldo regulable en altura.

353

versions
Medium
Medium+headrest

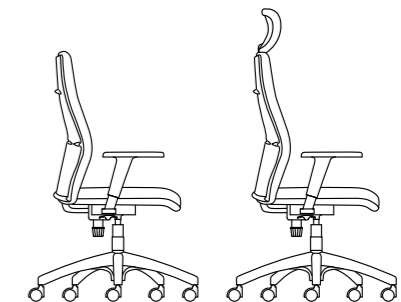



OtavoQ /Medium
OT0262+XT008+XB020

OtavoQ



OtavoQ /Medium+headrest
OT0262+XT008+XB020



OtavoQ /Medium
OT0262+XB020

OtavoQ

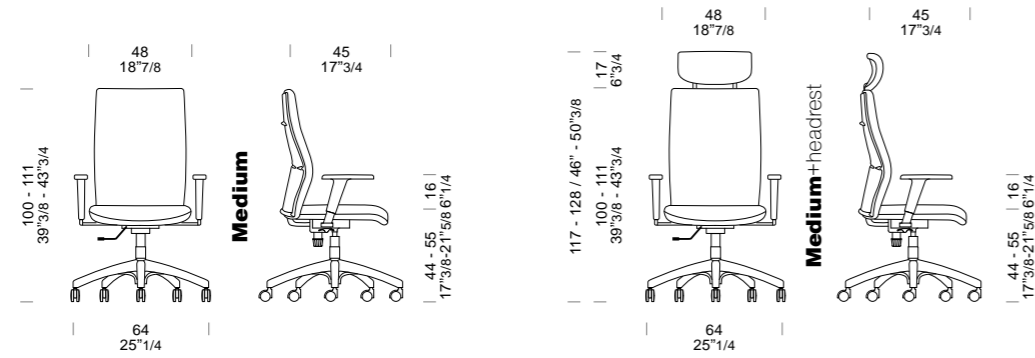

OtavoQ

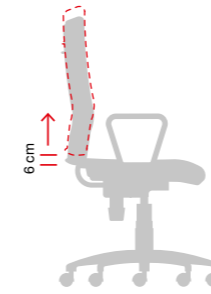

Schienale regolabile in altezza
 Height adjustable backrest
 Dossier réglable en hauteur
 Höhenverst. schwarz
 Respaldo ajustable en altura

SCHIENALE: Schienale regolabile in altezza (6cm) in polipropilene, finitura nera imbottita con spugna e rivestita in tessuto, con sostegno in tubo rettangolare d'acciaio, 60x20mm, finitura verniciata a polveri.

BACKREST: Black polypropylene height adjustable backrest (6cm), foam padding and fabric upholstery. Rect.60x20mm steel tube support, powder coated.

DOSSIER: Dossier réglable en hauteur (6cm) en polypropylène, finition noir rembourré de mousse et tapissé, avec soutien en tube d'acier rectangulaire, 60x20mm, finition verni époxy.

RÜCKENLEHNE: (6cm) Höhenverst. schwarze polypropylen Rückenlehne mit Schaumstoff, ausgepolstert. Vierkantstahlrohrstütze 60x20mm, pulverbeschichtet.

RESPALDO: Respaldo ajustable en altura (6 cm) en polipropileno, acabado negro acolchado con espuma y forrado en tela, con soporte en tubo de acero rectangular, 60x20 mm, acabado en polvo.

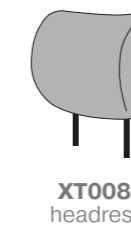
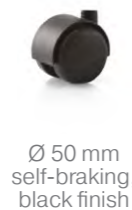
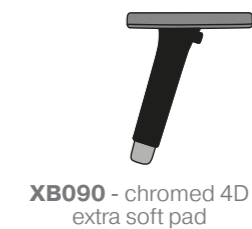
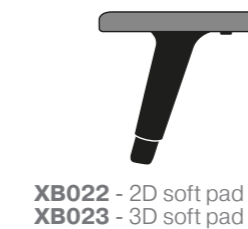

Per approfondimenti su meccanismi, braccioli e certificazioni consultare la sezione tecnica a pag. 24. / For further information on mechanisms, armrests and certifications, consult the technical section on page 24 / Pour plus d'informations sur les mécanismes, les accoudoirs et les certifications, consultez la section technique p. 24 / Weitere Informationen zu Mechanismen, Armlehnen und Zertifizierungen finden Sie im technischen Abschnitt auf Seite 24 / Para más información sobre mecanismos, brazos y certificaciones, consulte el apartado técnico en p. 24

